

“La Cupola” espresso maker 9095

Designed in the early 30s, the espresso maker is the last true “invention” among the various coffee making methods in use on our planet. Characterized by quick preparation, concentrated volume and the intense aroma and flavor of the coffee produced by passing water vertically upwards through the coffee grounds (Fig. 2), it does not just symbolize Italian coffee, but has also become the typical coffee making method in all the European countries of the Mediterranean basin. La Cupola was designed by Aldo Rossi in 1985.

The espresso maker is made of cast aluminum with a polyamide handle. The boiler has a thick flanged aluminum base to guarantee even heat distribution and shield the body from flame. The coffee maker construction layout is shown in Figure 1.

Available in three sizes: six cups (30 cl); three cups (15 cl); or one cup (7 cl).

IMPORTANT

Aluminum is an excellent conductor of heat and gives a characteristic flavor to espresso made in La Cupola thanks to the seasoning of the inner walls of the coffee maker with a thin film of coffee. In gastronomic terms, coffee prepared with La Cupola has a fuller and more rounded flavor than that made with a stainless steel coffee maker.

However, due to its physical characteristics, aluminum is much more susceptible to atmospheric impact than stainless steel: if the coffee maker is not used daily it should be disassembled and placed in a dry location. When used again, the first batch of coffee should be discarded in order to eliminate any unpleasant flavor. In humid environments small spots of oxidation may appear on the body of the espresso maker if not used for extended periods. These spots in no way affect the quality of the coffee produced.

ARTICLE NUMBERS BB9095 – CB9095

The material that covers the colored version of La Cupola coffee maker (art. no. BB9095 – CB9095) was specially developed for use in the home. Day to day knocks and impacts will not peel off the coating from the underlying aluminum, which will be

protected from the oxidizing effects of a humid environment. For proper care, please read the following instructions, and remember that exposure to excessive heat or the use of abrasive detergents may alter the finish, without, however, affecting the normal use of the coffee maker.

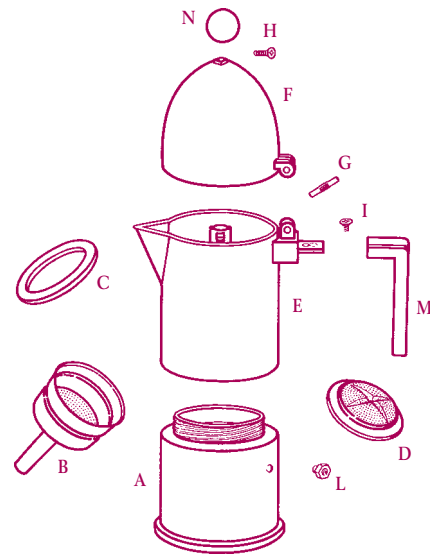

Fig. 1

Instructions

BEFORE USING THE ESPRESSO MACHINE FOR THE FIRST TIME, wash it out carefully with running water and dish soap. Make and discard several batches of coffee to eliminate any metallic taste.
FOR USE

FILL THE BOILER (A) with cold water making sure the water level remains below the safety valve (Fig. 3). Place the filter funnel (B) into the boiler (A).

FILL the filter funnel (B) to the brim with ground coffee and level it gently, without excessive pressure (Fig. 4). We recommend using coffee that is not too finely ground so that the boiling water will flow through easily but slowly and extract all the flavor. **MAKE SURE** that the upper filter plate (D) and the gasket (C) are properly seated in the bottom of the upper body of the coffee maker (E). Screw the upper body (E) firmly onto the boiler (A) (Fig. 5).

PLACE THE COFFEE MAKER ON THE BURNER. If you are using a gas burner, we recommend keeping the flame low (Fig. 6), to preserve the rubber gasket, keep the handle from being damaged and prevent scorching and discoloration of the aluminum.

As soon as the coffee has stopped percolating up through the central column in the upper part of the coffee maker (E), remove the coffee maker from the heat. Leaving the empty boiler on the burner may result in permanent damage to the coffee maker.

We advise **STIRRING** the coffee slowly with a small spoon to evenly mix it since the coffee bubbling up at the end tends to be weaker than that percolating up at the beginning. Pour the coffee into demitasses.
AFTER USE

Do not unscrew the coffee maker until it has cooled down.

CLEANING

We advise against using the dishwasher for cleaning purposes. Modern-day detergents and additives and the high temperatures reached during the wash cycle can cause irreparable damage to the surface finish of the product.

Disassemble the coffee maker and rinse all its parts under running water. Dry carefully.

Never wash the coffee maker with soap as this will alter the flavor of subsequent coffees. We recommend storing La Cupola, especially during extended periods of disuse, disassembled, in a dry and well-ventilated place, away from sources of moisture.

IMPORTANT

The inside of the column, the funnel, the filter plate, and the rubber gasket and its seat should be carefully cleaned periodically. Replace any worn parts.

REPLACEMENT PARTS:

Pieces B, C, D, H, I, L, M and N are considered spare parts. In case of loss or wear, contact your dealer indicating their reference numbers:

Six-cup model: B - 17703; C - 29709; D - 17705; H+N/B - 24007; H+N/AZ - 24011; L - 19660; M+I/B - 24005; M+I/AZ - 24009.

Three-cup model: B - 17702; C - 29708; D - 17704; H+N/B - 24006; H+N/AZ - 24010; L - 19660; M+I/B - 24004; M+I/AZ - 24008.

One-cup model: B - 17707; C - 29710; D

- 17706; H+N/B - 24019; H + N/AZ - 24018; L - 19660; M+I/B - 24016; M+I/AZ - 24017.

A - Boiler; B - Filter Funnel; C - Rubber Gasket; D - Upper Filter Plate; E - Upper Body with Column; F - Cover; G - Brass Hinge Pin; H - Knob Screw; I - Handle Screw; L - Safety Valve; M1 - Black Handle; M2 - Blue Handle; N1 - Black Knob; N2 - Blue Knob.

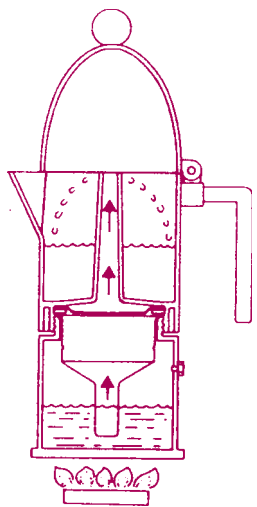

Fig. 2

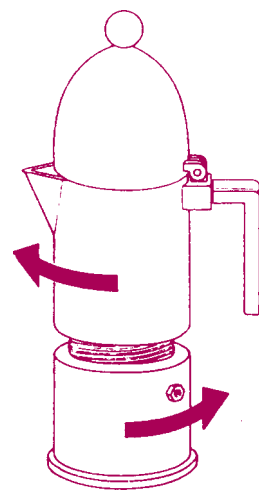

Fig. 5



Fig. 3

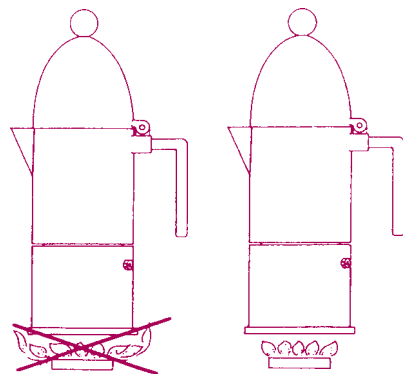

Fig. 6



Fig. 4

ALESSI

28882 Crusinallo (VB) Italia
tel. 0323 868611 fax 0323 641605
sac.alessi@alessi.it